



Patented manufacturing process produces battery cells for applications that require:

- Excellent energy density
- Excellent power-to-energy balance
- High cycle life
- Longer battery calendar life
- Low impedance and heat generation provide improved safety
- Lightweight



Advantages

Lower Cost/Consistent Quality/
Greater Reliability

- Proven chemistry with 10+ years in the field
- Nickel Manganese Cobalt (NMC) Li-Ion
- Prismatic (Flat Plate) Design
- Large Capacity Single Element Cell Design
- Scalable to mass produce cells
- Highly automated manufacturing
- Extended run time between charges

Applications

Ideal for High Current (Amp) Power applications where space and weight are restricted or limited.

- Transportation
 - Fully electric vehicles
 - Plug-in electric vehicles
- Military
- Aviation
- UPS (uninterrupted power supply)
- Motive Power
- Industrial Machinery
- Marine
- Grid Storage
- Telecom

Electrical Characteristics [at 25°C (77°F)]

Capacity (Nominal @ C/2)	31Ah	
Voltage (Nominal)	3.7V	
Lower Limit Voltage	2.7V	
Upper Limit Voltage	4.2V	
Charge Current (Max. Continuous)	93A (3C)	
Discharge Current (Max. Continuous)	248A (8C)	
Pulse Current (Max., 10 sec. Duration)	372A (12C)	
# Cycles @ 1C/1C (31A), to 80% of Capacity	100% DOD or 2.7-4.2V Greater than 2,700	80% DOD or 3.3-4.1V Greater than 5,000
Internal Impedance (1kHz AC)	0.70 mΩ	
Weight	0.77 Kg (1.70 lb)	
Peak Power Density (10 Sec., 50% SOC)		
Gravimetric	1811 W/Kg (823.2 W/lb)	
Volumetric*	3457 W/L (56.7 W/cu. inches)	
Energy Density		
Gravimetric	146 Wh/Kg (66.4 Wh/lb)	
Volumetric*	310 Wh/L (5.1 Wh/cu. inches)	

Operational Specifications

Charge Temperature Range	0°C ~ 45°C (32°F ~113°F)
Discharge Temperature Range	-20°C ~ 60°C (-4°F ~140°F)

*Volume calculated using core cell dimensions, excluding tabs and seals

SUPERIOR LITHIUM POLYMER CELL

Charge Profiles at Room Temperature

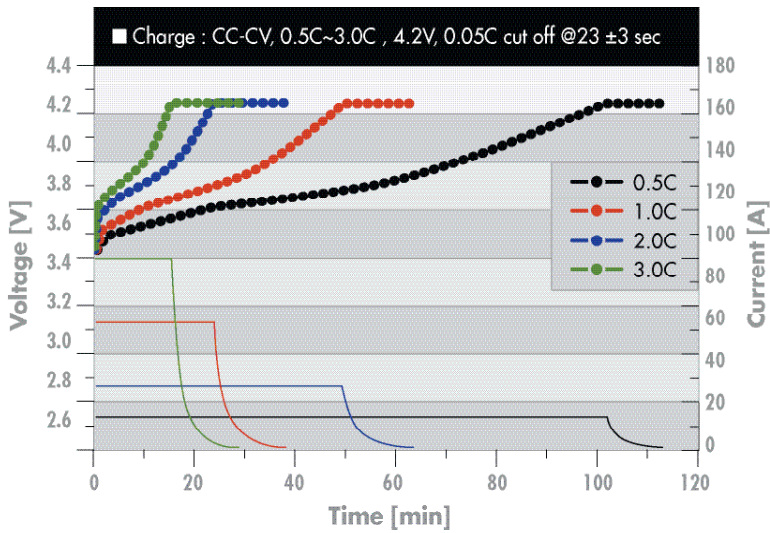

Temperature Characteristics

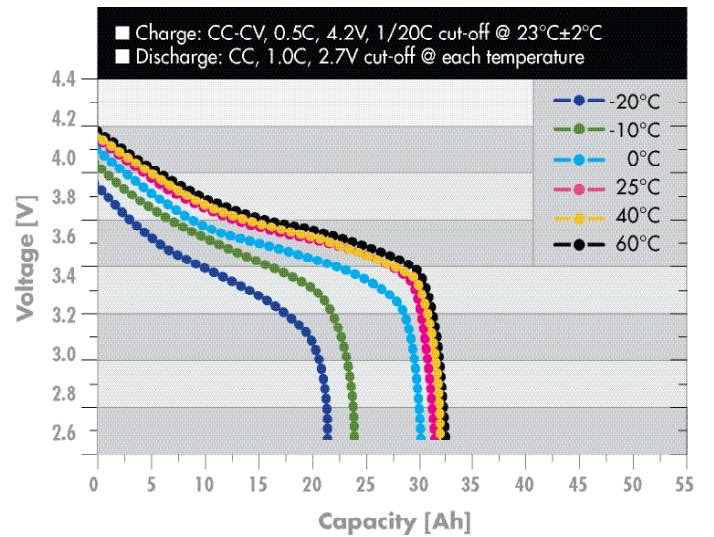

Discharge Profiles at Room Temperature

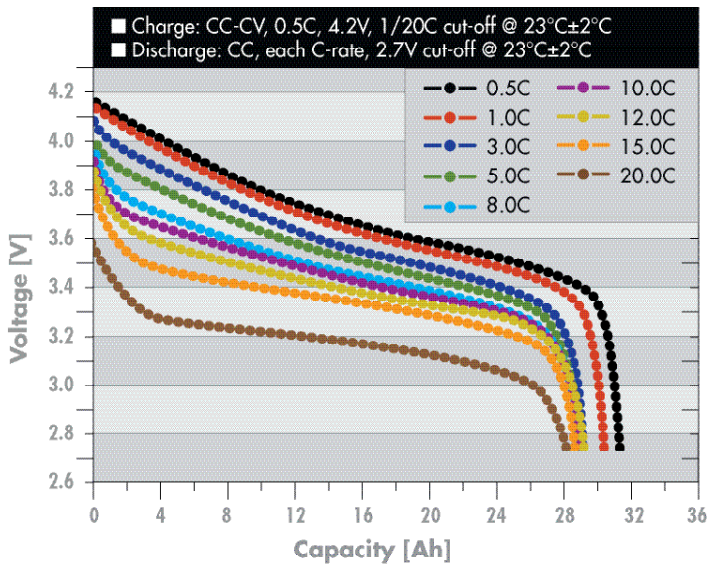

Mechanical Characteristics

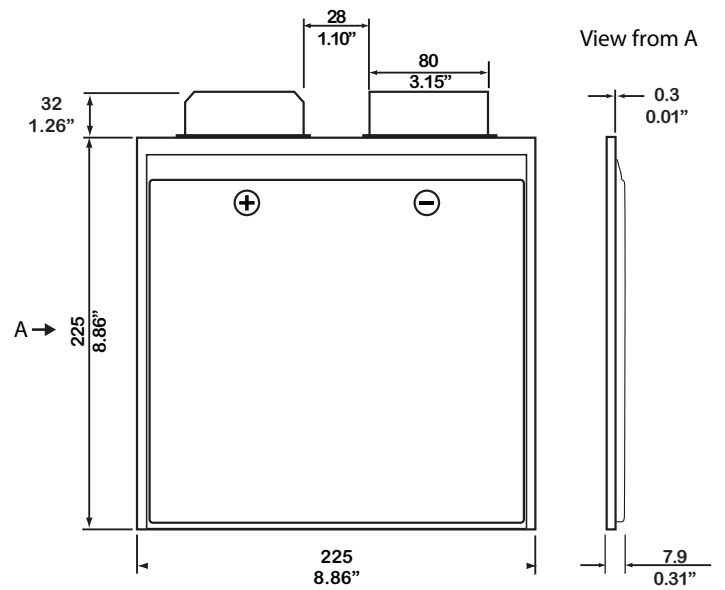

Note: dimensions shown in mm and inches (")



IEEE/UL Battery
 Sizing by
MooreU
 610-952-6067
 www.mooreu.com

2700 S. Saginaw Road, Midland, MI 48640 • +1 989 698 3300

Email: powerup@xaltenergy.com
 Web: xaltenergy.com

The information contained herein is provided solely for the purposes of general explanation and illustration, and is subject to modification without notice. No warranty or guarantee is given in regards to the information contained herein or the referenced products. Please contact XALT Energy for the most current and relevant product information for your particular application.