



# CL1000 2V 1000Ah(10hr)



The rechargeable batteries are lead-lead dioxide systems. The dilute sulfuric acid electrolyte is absorbed by separators and plates and thus immobilized. Should the battery be accidentally overcharged producing hydrogen and oxygen, special one-way valves allow the gases to escape thus avoiding excessive pressure build-up. Otherwise, the battery is completely sealed and is, therefore, maintenance-free, leak proof and usable in any position.

## Battery Construction

Component	Positive plate	Negative plate	Container	Cover	Safety valve	Terminal	Separator	Electrolyte
Raw material	Lead dioxide	Lead	ABS	ABS	Rubber	Copper	Fiberglass	Sulfuric acid

## General Features

- Absorbent Glass Mat (AGM) technology for efficient gas recombination of up to 99% and freedom from electrolyte maintenance or water adding.
- Not restricted for air transport-complies with IATA/ICAO Special Provision A67.
- UL-recognized component.
- Can be mounted in any orientation.
- Computer designed lead, calcium tin alloy grid for high power density.
- Long service life, float or cyclic applications.
- Maintenance-free operation.
- Low self discharge.

## Dimensions and Weight

Length(mm / inch)	475 / 18.70
Width(mm / inch)	175 / 6.89
Height(mm / inch)	328 / 12.91
Total Height(mm / inch)	367 / 14.5
Approx. Weight(Kg / lbs)	66.5 / 146.6

\* Weight deviation: ± 3%

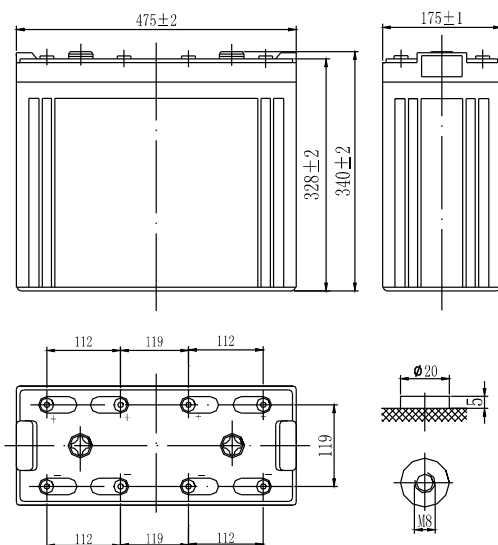

Total height with removable cover: 367

## Performance Characteristics

Nominal Voltage	2V
Number of cell	1
Design Life	20 years
Nominal Capacity 77°F(25°C)	
10 hour rate (100A, 1.8V)	1000Ah
5 hour rate (180A, 1.75V)	900Ah
1 hour rate (620A, 1.6V)	620Ah
Internal Resistance	
Fully Charged battery 77°F(25°C)	≤ 0.65mOhms
Self-Discharge	
3% of capacity declined per month at 20°C(average)	
Operating Temperature Range	
Discharge	-20~60°C
Charge	-10~60°C
Storage	-20~60°C
Max. Discharge Current 77°F(25°C)	4000A(5s)
Charge Methods: Constant Voltage Charge 77°F(25°C)	
Cycle use	2.40-2.45VPC
Maximum charging current	200A
Temperature compensation	-5.0mV/°C
Standby use	2.20-2.30VPC
Temperature compensation	-3.3mV/°C

## Discharge Constant Current (Amperes at 77°F25°C)

End Point Volts/Cell	15min	30min	45min	1h	3h	5h	10h
1.60V	1408	1063	758	620	261	195	108
1.65V	1340	1016	728	602	256	190	106
1.70V	1270	967	696	582	253	185	104
1.75V	1199	917	663	546	250	180	102
1.80V	1127	866	628	534	243	173	100

## Discharge Constant Power (Watts at 77°F25°C)

End Point Volts/Cell	15min	30min	45min	1h	2h	3h	5h
1.60V	2421	1804	1360	1114	720	522	360
1.65V	2290	1713	1298	1067	702	507	354
1.70V	2158	1621	1233	1018	688	497	348
1.75V	2024	1527	1166	967	676	488	341
1.80V	1890	1432	1099	915	661	476	335

(Note)The above characteristics data are average values obtained within three charge/discharge cycles not the minimum values. All data shall be changed without notice, Vision reserves the right to explain and update the information contained hereinto.

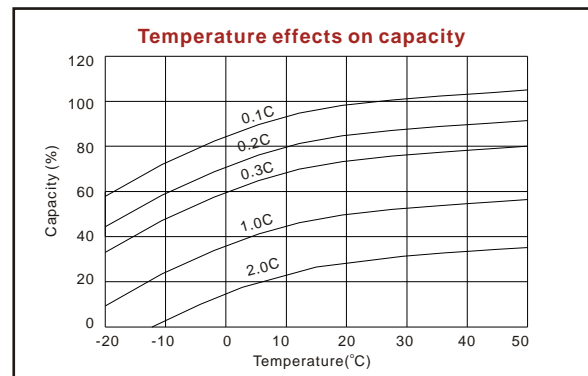
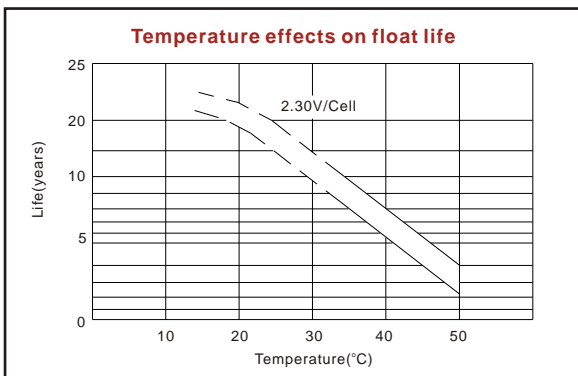
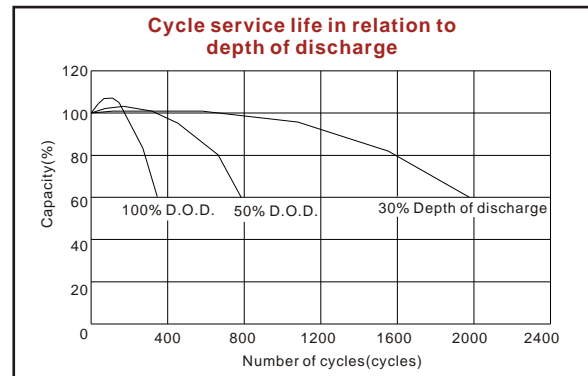
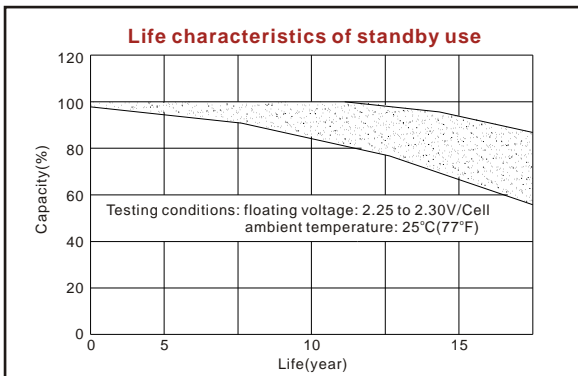
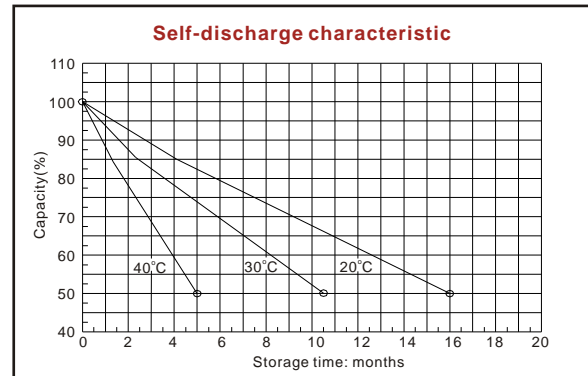
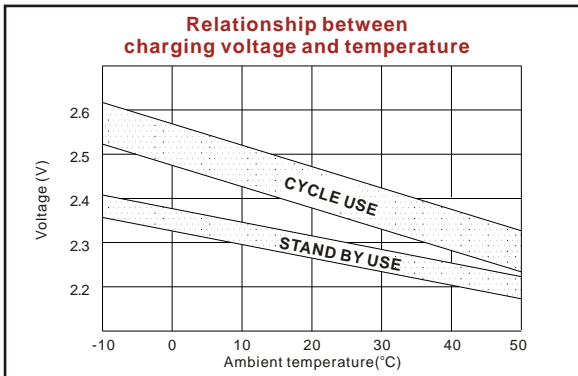
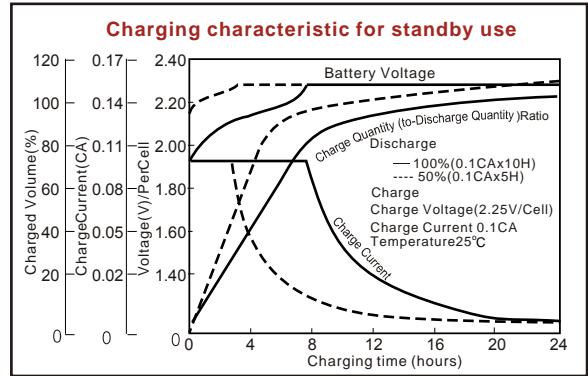
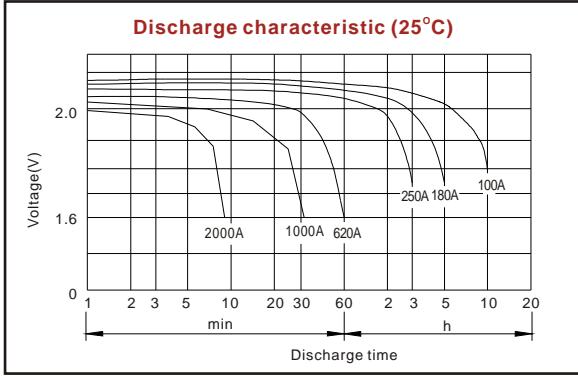

ISO9001:2008

MH25860

G4M19906-9202-E-16

[www.vision-batt.com](http://www.vision-batt.com)

**Shenzhen Center Power Tech. Co., Ltd.**  
Center Power Industrial Park, Tongfu Industrial District Dapeng Town, 518120 Shenzhen, China  
Tel: (+86-755) 8431 8088 Fax: (+86-755) 8431 8038 E-mail: sales@vision-batt.com