



SCP12550 22NF 12V 55Ah(20hr)

Rechargeable AGM Lead Acid batteries. Battery is completely sealed and is maintenance-free, leak proof, and can be used in any position. Is approved for transportation by Air, DOT, IATA, and FAA.

General Features

- Absorbent Glass Mat (AGM) technology for efficient gas recombination of up to 99%.
- Not restricted for air transportation, complies with IATA/ICAO special provision 67
- UL-recognized component
- Computer designed lead, calcium tin alloy grid for high power density
- Long service life, float or cyclic applications
- Maintenance-Free
- Low self-discharge

Dimensions and Weight

Length (mm / inch)	229/9.01
Width (mm / inch)	138/5.43
Height (mm / inch)	208/8.18
Total Height (mm / inch)	213/8.38
Aprox. Weight (kg / lbs)	15.3/33.7
Terminal Type/size	M6

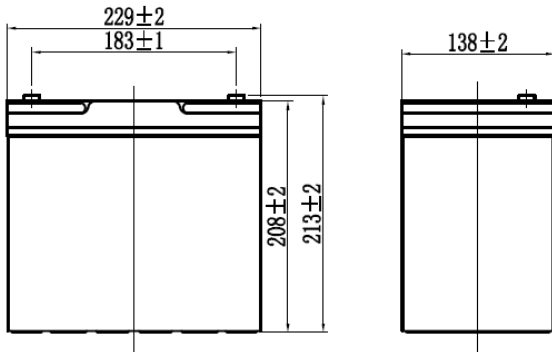

Performance Characteristics

Nominal voltage	12
Number of cells	6
Nominal Capacity 77° F (25°C)	
100 hour rate	1.80V/cell 64.3Ahr
24 hour rate	1.80V/cell 58.5Ahr
10 hour rate	1.80V/cell 53.0Ahr
5 hour rate	1.75V/cell 46.2Ahr
1 hour rate	1.60V/cell 35.1Ahr
Self-Discharge	
3% of capacity per month at 20°C	
Operating Temperature Range	
Discharge	-20 to +60°C
Charge	-10 to +60°C
Storage	-20 to +60°C
Max Discharge Current	550A
Short Circuit Current	1400A
Charge Methods: Constant Voltage Charge 77° F (25°C)	
Cycle use	2.40-2.45VPC
Maximum charging current	0.33C 20hr
Temperature compensation	-30mV/°C
Standby use	2.26-2.30VPC
Temperature compensation	-20mV/°C

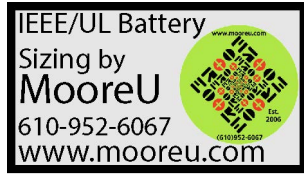

SCP12550 22NF 12V 55Ah(20hr)

