



VISION Rechargeable Products
Sealed Lead Acid Battery

www.vision-batt.com



UNA Series

High Rate Discharge

The new VISION UNA series batteries are specially designed for applications where need high power output. By optimum design of battery grids and plate paste formula, the UNA series can deliver up to 40% more power than VISION standard CP/FM series.

Shenzhen Center Power Tech Co., Ltd has more than 20 year's experience in the manufacturing of VRLA batteries.

SZCPT is one of the largest manufacturers of SLA (or VRLA) batteries in the world, the largest one in Mainland China and the first in China to develop and commercialize the sealed lead-acid battery with brand name VISION and has been at the forefront of battery technology from day one.

SZCPT leads the world in innovative battery technology. Our global network of sales and service engineers, backed in turn by our agents and distributors, means that we are currently active in more than 100 countries.

Shenzhen Center Power Tech. Co., Ltd

UNA12-150W 12V 150W

(Edition 2014-9)

General Features

- Positive and negative plates in lead-calcium tinalloy
- Superior energy density
- Operates at a low internal pressure.
- Gas Recombination
- Usable in any orientation
- A recognized component of UL
- Very high power output
- Application specific designs
- A couple Range from 90W to 540W per cell for 15' @ 1.67Vpc
- Six months shelf life at 20°C
- Design life 10 years



Dimensions and Weight

	Metric Units	English Units
Length	195mm	7.68inch
Width	130mm	5.12inch
Height	155mm	6.10inch
Total Height	168mm	6.61inch
Approx. Weight	13.0Kg	28.7lbs

Performance Characteristics

- Nominal Voltage 12V
- Number of cell 6
- Nominal Capacity 77°F(25°C)
 - 15 min wattage @ 1.67V 150W/cell
 - 10 hour rate (3.30A, 10.8V) 33.0Ah
- Torque setting: 8.5NM
- Internal Resistance
 - Fully Charged battery 77°F(25°C) ≤ 7.0mOhms
- Self-Discharge
 - 3% of capacity declined per month at 20°C(average)
- Operating Temperature Range
 - Discharge -20~60°C
 - Charge -10~60°C
 - Storage -20~60°C
- Max. Discharge Current 77°F(25°C) 330A(5s)
- Charge Methods: Constant Voltage Charge 77°F(25°C)
 - Cycle use 2.40-2.45VPC
 - Maximum charging current 9.9A
 - Temperature compensation -30mV/°C
- Standby use 2.20-2.30VPC
 - Temperature compensation -20mV/°C



Center Power Industrial Park, Tongfu Industrial District Dapeng Town, 518120 Shenzhen, China
Tel: 86 755 84318088 Fax: 86 755 84318038 E-mail: sales@vision-batt.com
Website: <http://www.vision-batt.com>

UNA12-150W 12V 150W

Discharge Data

Constant Current Discharge Data (Ampere at 25 °C)

End Voltage Volts/Cell	5min	10min	15min	20min	30min	40min	50min	60min
1.60	165	115	86.7	69.5	50.4	40.0	33.5	28.9
1.67	150	106	82.1	66.1	48.4	38.5	32.5	28.5
1.70	142	102	80.0	64.5	47.5	38.0	32.1	28.4
1.75	130	96.5	76.0	62.0	45.7	36.5	30.8	27.8
1.80	118	90.0	71.0	58.2	43.8	35.0	29.7	26.8

Constant Power Discharge Data (Watts at 25 °C)

End Voltage Volts/Cell	5min	10min	15min	20min	30min	40min	50min	60min
1.60	298	210	152	131	96.0	77.0	64.5	55.7
1.67	270	197	150	125	93.0	75.0	64.2	55.6
1.70	258	190	146	122	91.1	73.5	63.5	55.3
1.75	237	179	137	117	88.3	71.2	62.3	54.0
1.80	215	167	131	112	85.2	68.3	60.2	52.1

(Note) The above characteristics data are average values obtained within three charge/discharge cycles not the minimum values.
All data shall be changed without notice, Vision reserves the right to explain and update the information contained hereinto.

Performance drawings

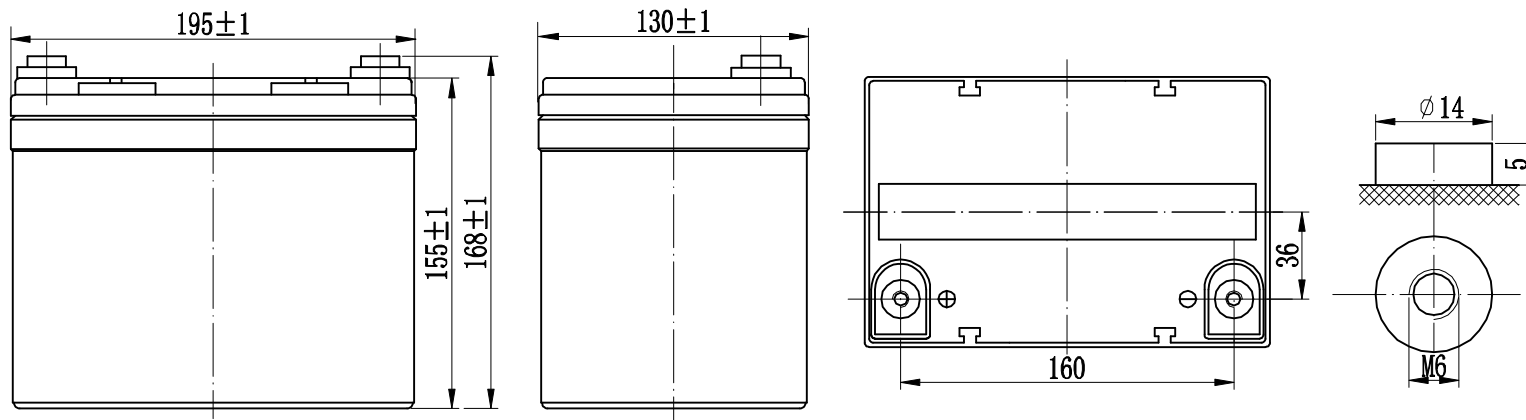

UNA12-150 12V 150W

