

IEEE/UL Battery  
Sizing by  
**MooreU**  
610-952-6067  
www.mooreu.com

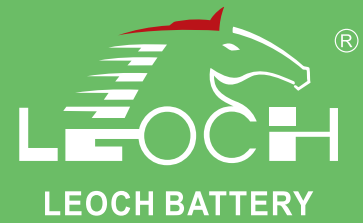

# OPzS Series-Flooded Battery

## 4 OPzS200(2V200Ah)



### Specifications

Rated Voltage	2V	
Nominal Capacity	$C_{10}, 1.80V/cell$	200.0Ah
Dimension	Length	103±2mm (4.06 inches)
	Width	206±2mm (8.11 inches)
	Container Height	355±3mm (13.98 inches)
	Total Height	410±3mm (16.14 inches)
Approx Weight	Without Electrolyte 12.9kg (28.44lbs) With Electrolyte 17.4 kg (38.37lbs)	
Terminal	M10	
Container Material	SAN transparent container	
Rated Capacity	200.0 Ah	(10hr, 20.0A, 1.80V/cell)
	177.5 Ah	(5hr, 35.5A, 1.75V/cell)
	154.2 Ah	(3hr, 51.4A, 1.75V/cell)
	114.2 Ah	(1hr, 114.2A, 1.60V/cell)
Max. Discharge Current	1600A (5s)	
Internal Resistance (20°C)	Approx 1.20mΩ	
Operating Temp. Range	Discharge	-15 ~ 55°C (5 ~ 131°F)
	Charge	0 ~ 45°C (32 ~ 113°F)
	Storage	-15 ~ 45°C (5 ~ 113°F)
Nominal Operating Temp. Range	25±5°C (77±9°F)	
Cycle Use	Initial Charging Current less than 0.15CA. Voltage 2.40V~2.45V at 20°C(68°F)Temp. Coefficient -5mV/°C	
	Standby Use	
Effect of temp. to Capacity	Initial Charging Current less than 0.15CA. Voltage 2.23V~2.25V at 20°C(68°F)Temp. Coefficient -3mV/°C	
	40°C (104°F)	103%
	20°C (68°F)	100%
Self Discharge	0°C (32°F)	86%
	≤4% per month at 20°C	



### Layout

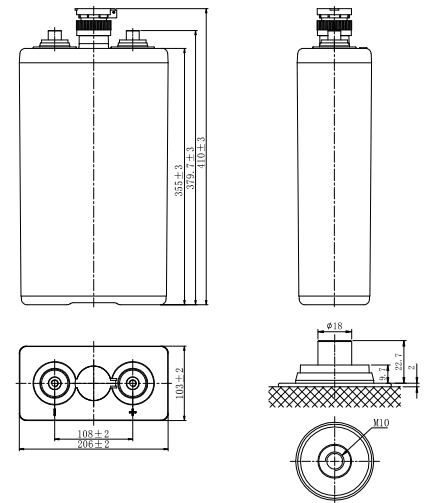

### Constant Current Discharge (Amperes) at 20 °C (68°F)

F. V/Time	1h	2h	3h	4h	5h	6h	8h	10h	20h	24h	72h	100h	120h
1.85V/cell	79.4	58.0	44.7	37.0	31.9	28.0	22.8	19.1	10.5	8.81	3.16	2.37	2.03
1.80V/cell	92.8	63.9	48.8	40.0	34.1	29.8	24.0	20.0	10.9	9.14	3.28	2.46	2.10
1.75V/cell	100.8	68.0	51.4	41.8	35.5	30.9	24.7	20.4	11.1	9.31	3.34	2.50	2.14
1.70V/cell	106.2	71.0	53.1	43.1	36.5	31.7	25.1	20.8	11.3	/	/	/	/
1.65V/cell	110.4	72.7	54.7	44.1	37.3	32.3	25.6	21.1	11.5	/	/	/	/
1.60V/cell	114.2	74.4	55.6	44.7	37.8	32.7	25.9	21.4	11.6	/	/	/	/

### Constant Power Discharge (Watts/cell) at 20 °C (68°F)

F. V/Time	1h	2h	3h	4h	5h	6h	8h	10h	20h	24h	72h	100h	120h
1.85V/cell	148.6	109.4	84.7	70.4	61.0	53.8	44.1	37.1	20.5	17.2	6.12	4.57	3.91
1.80V/cell	171.1	119.2	91.5	75.3	64.5	56.7	46.0	38.5	21.1	17.7	6.30	4.70	4.02
1.75V/cell	183.5	125.7	95.7	78.2	67.0	58.5	47.0	39.1	21.4	17.9	6.39	4.77	4.08
1.70V/cell	191.6	130.3	98.2	80.2	68.5	59.8	47.7	39.6	21.7	/	/	/	/
1.65V/cell	197.6	132.9	100.6	81.8	69.7	60.7	48.3	40.1	21.9	/	/	/	/
1.60V/cell	202.8	135.3	101.8	82.6	70.3	61.3	48.7	40.4	22.0	/	/	/	/



# OPzS Series-Flooded Battery

## 4 OPzS200(2V200Ah)



### Applications

- Telecommunications
- Buoy lighting
- Standby power
- Railway signalling
- Emergency lighting systems
- Alternative power (solar, wind)
- Maritime standby power on ships and ashore

### General Features

- 20 years design life(20°C)
- Lower self discharge
- Higher thermal capacity, no thermal runaway will occur
- Superior deep cycle performance
- Wide operation temperature range

### Standards

- Acc. to IEC60896, DIN 40736 standards
- Manufactured in Leoch@IATF 16949, ISO 45001, ISO 9001 and ISO 14001 certified production facilities

### Discharge Characteristics

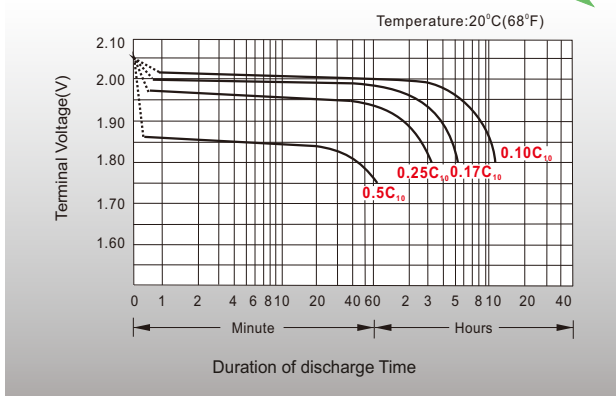

### Charge voltage Vs ambient temperature curve

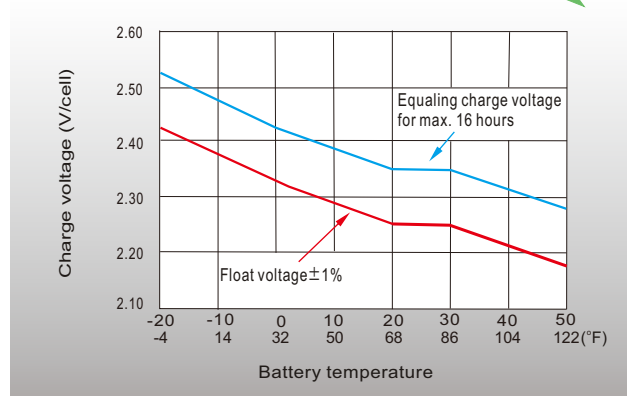

### Discharge capacity Vs Ambient temperature curve (I10A)

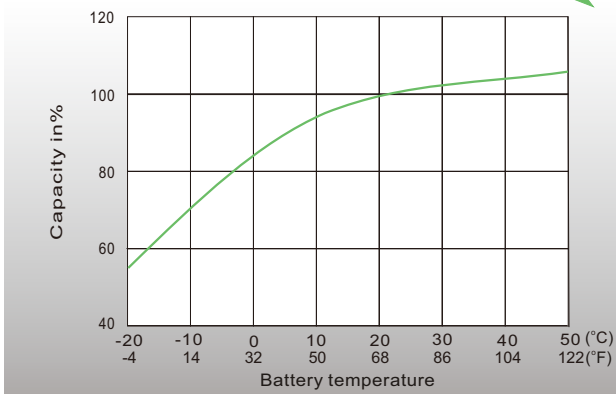

### Effect of Temperature on Long Term Float Life

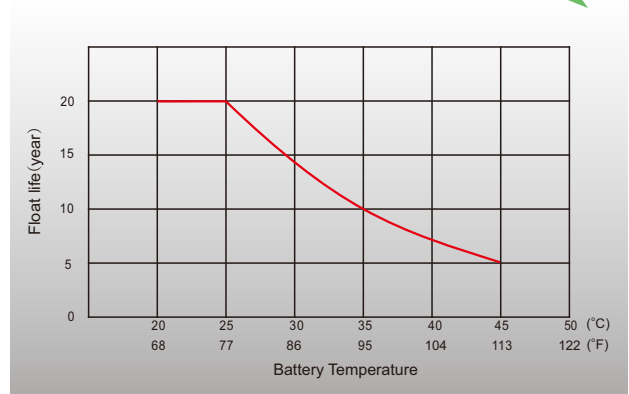

## Sales Offices Worldwide

#### China Sales Office

5th Floor, Xinbaohui Bldg., Nanhai Blvd.,  
Nanshan, Shenzhen, China. 518052  
Tel: +86-755-86036060 (100 lines)  
Fax: +86-755-26067269  
E-mail: export@leoch.com

#### HongKong Sales Office

Workshop C, 33/F, TML Tower, No. 3 Hoi Shing Road,  
Tsuen Wan, New Territories, Hong Kong  
Tel: +852 35786666  
Fax: +44 1452 690125  
E-mail: sales.hk@leoch.com

#### Singapore Sales Office

No. 1 Tech Park Crescent,  
Singapore 638131  
Tel: +65 68636078  
Fax: +65 6863 6079  
Email: sales.sg@Leoch.com

#### Australia Sales Office

2/29 Tarlington Place, Smithfield. NSW 2164  
Australia  
Tel: 02 9756 0950  
E-mail: sales.au@leoch.com

#### North America Sales Office

19751 Descartes  
Foothill Ranch, CA 92610, USA  
Tel: 949-588-5853  
Fax: 949-588-5966  
E-mail: sales@leoch.us

#### UK Sales Office

9B Wheatstone Court, Waterwells, Business Park,  
Gloucester, GL2-2AQ, UK United Kingdom  
Tel: +44(0) 1452 729428 / 1452 729696  
Fax: +44 1452 690125  
E-mail: Sales.Europe@leoch.com

#### EMEA Sales Office

1 Deligiorgi St., 121 31 Athens,  
Greece  
Tel: +30 210 5760318 (2 lines)  
E-mail: support\_EMEA@leoch.com

#### India Sales Office

Shed no.A-53(b), 2nd Stage of Peenya Industrial Area,  
Bangalore North Taluk, Bangalore-560058, India  
Tel: +91-80-23440018/23440019  
Fax: +91-80-23440017  
E-mail: indiasales@leoch.com

