

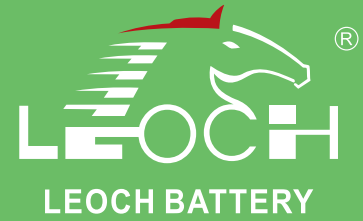

OPzS Series-Flooded Battery

3 OPzS150(2V150Ah)



Specifications

Rated Voltage	2V	
Nominal Capacity	$C_{10}, 1.80V/cell$	150.0Ah
Dimension	Length	103±2mm (4.06 inches)
	Width	206±2mm (8.11 inches)
	Container Height	355±3mm (13.98 inches)
	Total Height	410±3mm (16.14 inches)
Approx Weight	Without Electrolyte	10.8kg (23.8lbs)
	With Electrolyte	15.3 kg (33.7lbs)
Terminal	M10	
Container Material	SAN transparent container	
Rated Capacity	150.0 Ah	(10hr, 15.0A, 1.80V/cell)
	133.0 Ah	(5hr, 26.6A, 1.75V/cell)
	115.8 Ah	(3hr, 38.6A, 1.75V/cell)
	85.7 Ah	(1hr, 85.7A, 1.60V/cell)
Max. Discharge Current	1200A (5s)	
Internal Resistance (20°C)	Approx 1.15mΩ	
Operating Temp. Range	Discharge	-15 ~ 55°C (5 ~ 131°F)
	Charge	0 ~ 45°C (32 ~ 113°F)
	Storage	-15 ~ 45°C (5 ~ 113°F)
Nominal Operating Temp. Range	25±5°C (77±9°F)	
Cycle Use	Initial Charging Current less than 0.15CA. Voltage 2.40V~2.45V at 20°C(68°F)Temp. Coefficient -5mV/°C	
	Standby Use	
Effect of temp. to Capacity	40°C (104°F)	103%
	20°C (68°F)	100%
	0°C (32°F)	86%
Self Discharge	≤4% per month at 20°C	



Layout

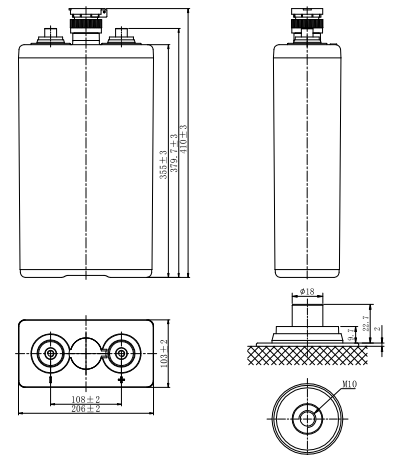

Constant Current Discharge (Amperes) at 20 °C (68°F)

F.V/Time	1h	2h	3h	4h	5h	6h	8h	10h	20h	24h	72h	100h	120h
1.85V/cell	59.6	43.5	33.5	27.7	23.9	21.0	17.1	14.4	7.88	6.61	2.37	1.78	1.53
1.80V/cell	69.6	47.9	36.6	30.0	25.5	22.3	18.0	15.0	8.20	6.88	2.47	1.85	1.59
1.75V/cell	75.6	51.0	38.6	31.3	26.6	23.2	18.5	15.3	8.36	7.01	2.52	1.89	1.62
1.70V/cell	79.7	53.3	39.8	32.3	27.4	23.7	18.8	15.6	8.50	/	/	/	/
1.65V/cell	82.8	54.5	41.0	33.0	28.0	24.2	19.2	15.9	8.62	/	/	/	/
1.60V/cell	85.7	55.8	41.7	33.5	28.4	24.5	19.4	16.0	8.70	/	/	/	/

Constant Power Discharge (Watts/cell) at 20 °C (68°F)

F.V/Time	1h	2h	3h	4h	5h	6h	8h	10h	20h	24h	72h	100h	120h
1.85V/cell	111.4	82.0	63.5	52.8	45.8	40.4	33.1	27.8	15.3	12.8	4.57	3.42	2.92
1.80V/cell	128.3	89.4	68.6	56.5	48.4	42.5	34.5	28.8	15.8	13.2	4.72	3.53	3.02
1.75V/cell	137.7	94.3	71.7	58.6	50.2	43.9	35.3	29.3	16.0	13.4	4.78	3.57	3.05
1.70V/cell	143.7	97.7	73.6	60.2	51.4	44.8	35.8	29.7	16.2	/	/	/	/
1.65V/cell	148.2	99.6	75.5	61.3	52.3	45.5	36.3	30.1	16.4	/	/	/	/
1.60V/cell	152.1	101.5	76.4	61.9	52.7	45.9	36.5	30.3	16.5	/	/	/	/



OPzS Series-Flooded Battery

3 OPzS150(2V150Ah)

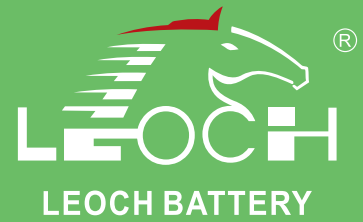

Applications

- Telecommunications
- Buoy lighting
- Standby power
- Railway signalling
- Emergency lighting systems
- Alternative power (solar, wind)
- Maritime standby power on ships and ashore

General Features

- 20 years design life(20°C)
- Lower self discharge
- Higher thermal capacity, no thermal runaway will occur
- Superior deep cycle performance
- Wide operation temperature range

Standards

- Acc. to IEC60896, DIN 40736 standards
- Manufactured in Leoch@IATF 16949, ISO 45001, ISO 9001 and ISO 14001 certified production facilities

Discharge Characteristics

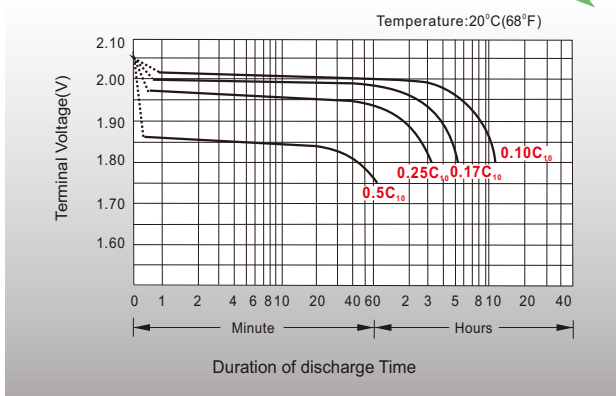

Charge voltage Vs ambient temperature curve

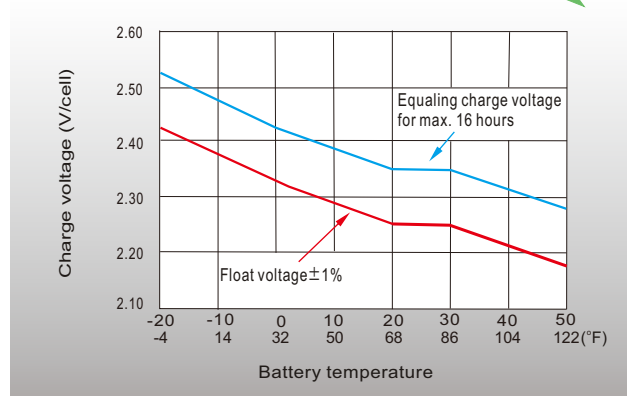

Discharge capacity Vs Ambient temperature curve (10A)

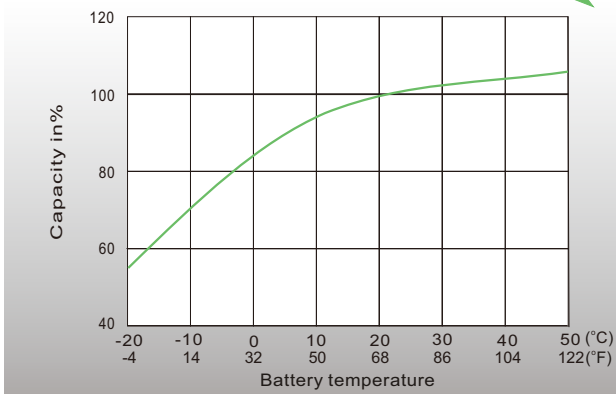

Effect of Temperature on Long Term Float Life

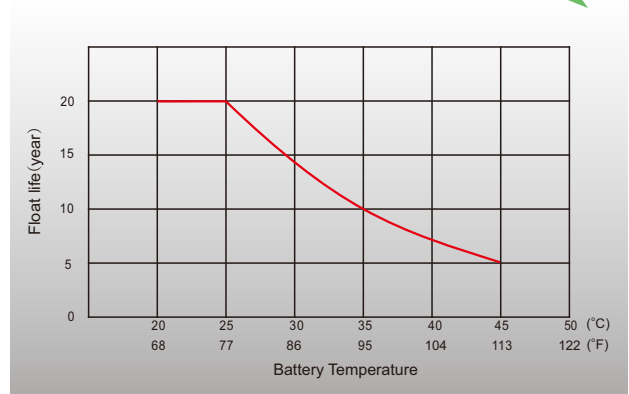

Sales Offices Worldwide

China Sales Office

5th Floor, Xinbaohui Bldg., Nanhai Blvd.,
Nanshan, Shenzhen, China. 518052
Tel: +86-755-86036060 (100 lines)
Fax: +86-755-26067269
E-mail: export@leoch.com

HongKong Sales Office

Workshop C, 33/F, TML Tower, No. 3 Hoi Shing Road,
Tsuen Wan, New Territories, Hong Kong
Tel: +852 35786666
Fax: +44 1452 690125
E-mail: sales.hk@leoch.com

Singapore Sales Office

No. 1 Tech Park Crescent,
Singapore 638131
Tel: +65 68636078
Fax: +65 6863 6079
Email: sales.sg@Leoch.com

Australia Sales Office

2/29 Tarlington Place, Smithfield. NSW 2164
Australia
Tel: 02 9756 0950
E-mail: sales.au@leoch.com

North America Sales Office

19751 Descartes
Foothill Ranch, CA 92610, USA
Tel: 949-588-5853
Fax: 949-588-5966
E-mail: sales@leoch.us

UK Sales Office

9B Wheatstone Court. Waterwells, Business Park,
Gloucester, GL2-2AQ, UK United Kingdom
Tel: +44(0) 1452 729428 / 1452 729696
Fax: +44 1452 690125
E-mail: Sales.Europe@leoch.com

EMEA Sales Office

1 Deligiorgi St., 121 31 Athens,
Greece
Tel: +30 210 5760318 (2 lines)
E-mail: support_EMEA@leoch.com

India Sales Office

Shed no.A-53(b), 2nd Stage of Peenya Industrial Area,
Bangalore North Taluk, Bangalore-560058, India
Tel: +91-80-23440018/23440019
Fax: +91-80-23440017
E-mail: indiasales@leoch.com

