

OPzV12-80(12V80Ah)



Ritar OPzV series is Valve Regulated Lead Acid battery that adopts immobilized GEL and Tubular Plate technology to offer high reliability and performance. The Battery is designed and manufactured according to DIN standards and with die-casting positive grid and patented formula of active material OPzV series exceeds DIN standard values with more than 18 years floating design life at 25 °C ,and It is the best solution for cyclic use under extreme operating conditions.

Specification

| | |
|---|---|
| Cells Per Unit | 6 |
| Voltage Per Unit | 12 |
| Nominal Capacity | 80Ah@10hr-rate to 1.80V per cell @25°C |
| Weight | Approx. 30.0 Kg (Tolerance±2%) |
| Internal Resistance | Approx. 10 mΩ |
| Terminal | F5(M8)/F12(M8) |
| Max. Discharge Current | 800A (5 sec) |
| Design Life | 18 years (floating charge) |
| Maximum Charging Current | 16.0 A |
| Reference Capacity | C24 80.56AH C48 85.12AH C72 89.38AH C100 91.20AH C120 93.02AH C240 98.50AH |
| Float Charging Voltage | 13.5 V~13.8 V @ 25°C Temperature Compensation: -3mV/°C/Cell |
| Cycle Use Voltage | 14.2 V~14.4 V @ 25°C Temperature Compensation: -4mV/°C/Cell |
| Operating Temperature Range | Discharge: -40°C~60°C Charge: -20°C~50°C Storage: -40°C~60°C |
| Normal Operating Temperature Range | 25°C±5°C |
| Self Discharge | RITAR Valve Regulated Lead Acid (VRLA) batteries can be stored for up to 6 months at 25°C and then recharging is recommended. Monthly Self-discharge ratio is less than 2% at 25°C.Please charged batteries before using. |
| Container Material | A.B.S. UL94-HB, UL94-V0 Optional. |



Dimensions

Unit: mm

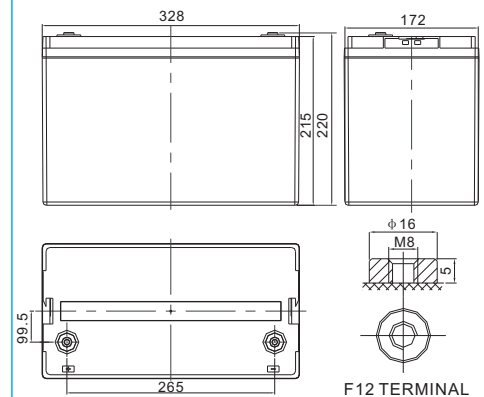

| | |
|--------------|-----------------------|
| Length | 328±1mm (12.9 inches) |
| Width | 172±1mm (6.77 inches) |
| Height | 215±1mm (8.46 inches) |
| Total Height | 220±1mm (8.66 inches) |
| Torque Value | 10~12 N*m |

Constant Current Discharge Characteristics :A(25°C)

| F.V/ Time | 30min | 1h | 2h | 3h | 4h | 5h | 6h | 8h | 10h | 20h |
|-----------|-------|-------|-------|-------|-------|-------|-------|-------|-------|-------|
| 1.90V | 39.36 | 31.20 | 22.01 | 16.68 | 13.68 | 11.82 | 10.64 | 8.304 | 7.120 | 3.739 |
| 1.87V | 44.00 | 34.40 | 23.61 | 17.69 | 14.44 | 12.44 | 11.28 | 8.692 | 7.440 | 3.906 |
| 1.83V | 50.40 | 38.40 | 25.60 | 18.86 | 15.20 | 12.97 | 11.68 | 9.079 | 7.760 | 4.075 |
| 1.80V | 56.00 | 41.60 | 26.56 | 19.40 | 15.50 | 13.28 | 12.00 | 9.312 | 8.000 | 4.201 |
| 1.75V | 62.40 | 44.57 | 27.77 | 20.18 | 15.76 | 13.60 | 12.24 | 9.467 | 8.160 | 4.284 |
| 1.70V | 68.80 | 46.01 | 28.57 | 20.57 | 16.04 | 13.76 | 12.40 | 9.545 | 8.240 | 4.325 |
| 1.65V | 70.97 | 48.89 | 29.53 | 21.12 | 16.26 | 13.92 | 12.56 | 9.623 | 8.320 | 4.368 |
| 1.60V | 74.01 | 50.56 | 30.65 | 22.01 | 16.72 | 14.16 | 12.72 | 9.700 | 8.400 | 4.411 |

Constant Power Discharge Characteristics : WPC(25°C)

| F.V/ Time | 30min | 1h | 2h | 3h | 4h | 5h | 6h | 8h | 10h | 20h |
|-----------|-------|-------|-------|-------|-------|-------|-------|-------|-------|-------|
| 1.90V | 75.35 | 59.91 | 42.52 | 32.33 | 26.79 | 23.28 | 21.04 | 16.61 | 14.51 | 7.618 |
| 1.87V | 82.90 | 65.04 | 45.10 | 33.87 | 28.21 | 24.40 | 22.24 | 17.30 | 15.13 | 7.944 |
| 1.83V | 92.86 | 70.90 | 48.00 | 35.61 | 29.60 | 25.36 | 22.96 | 17.93 | 15.67 | 8.228 |
| 1.80V | 101.5 | 75.64 | 49.60 | 36.41 | 30.16 | 25.92 | 23.52 | 18.31 | 16.06 | 8.433 |
| 1.75V | 110.1 | 79.02 | 51.20 | 37.54 | 30.55 | 26.56 | 23.92 | 18.55 | 16.30 | 8.554 |
| 1.70V | 118.0 | 79.85 | 52.50 | 38.16 | 31.02 | 26.80 | 24.16 | 18.70 | 16.45 | 8.637 |
| 1.65V | 120.0 | 83.38 | 53.96 | 39.02 | 31.44 | 27.04 | 24.40 | 18.86 | 16.53 | 8.679 |
| 1.60V | 121.5 | 85.96 | 55.23 | 40.30 | 32.24 | 27.28 | 24.56 | 18.93 | 16.61 | 8.717 |

(Note) The above characteristics data are average values obtained within three charge/discharge cycle not the minimum values.

OPzV12-80(12V80Ah)



Discharge Characteristics Curve

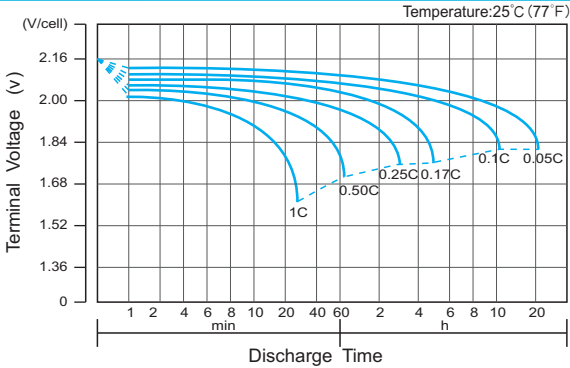

Charge Characteristic Curve for Cycle Use(IU)

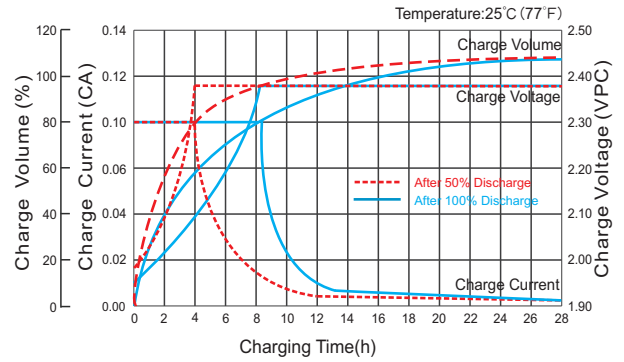

Cycle Life in Relation to Depth of Discharge

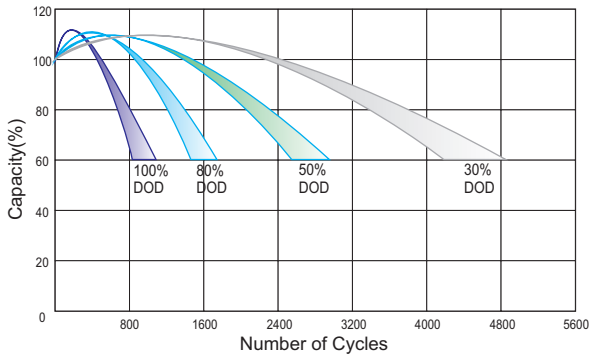

Relationship Between Charging Voltage and Temperature

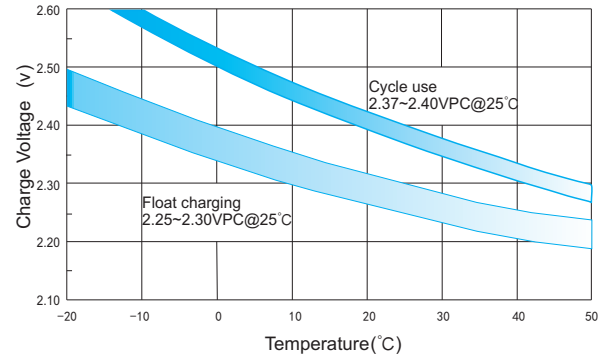

Temperature Effects on Capacity

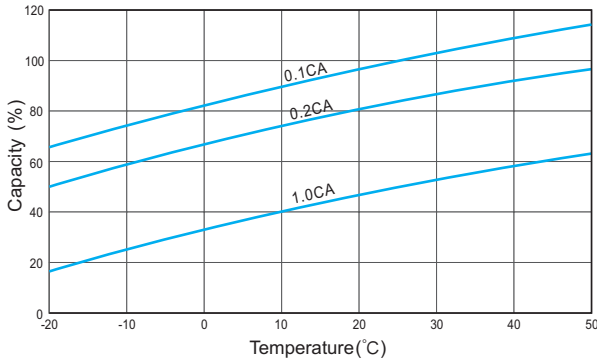

Storage Characteristics

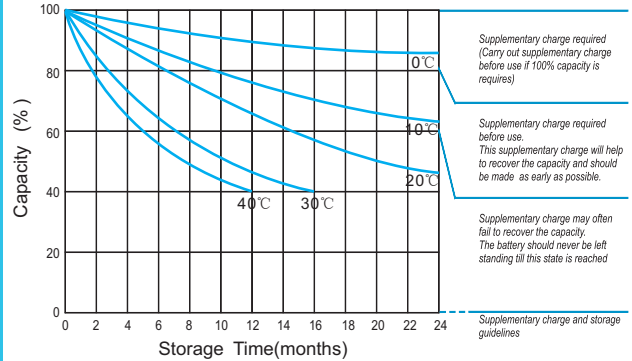

Effect of Temperature on Long Term Life

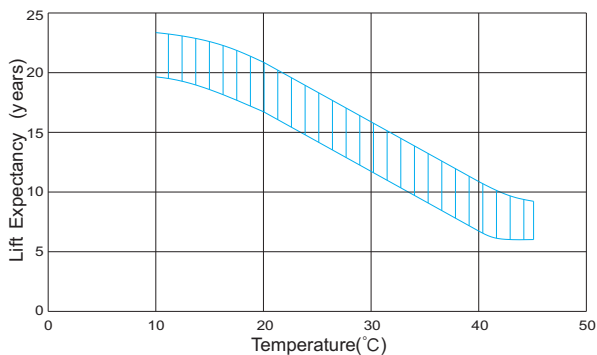

Relationship of OCV And State of Charge(20°C)

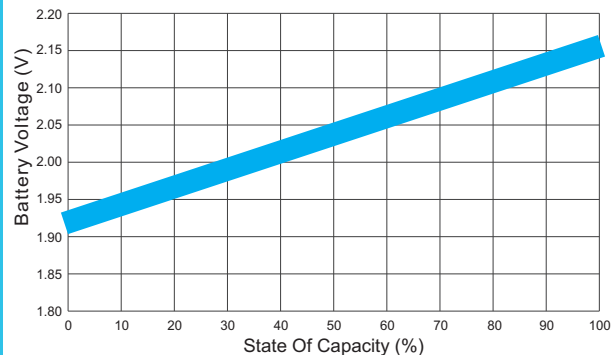

For Battery Sales + EPA Battery Recycling and AC / DC Power Services, please contact:
Moore & Moore Solutions, Inc.
Phone: 484-302-7009
Email: mr@mooreu.com
www.MooreU.com